

BMS Connection

(These instructions are for EVA REV Resistor Bleeding 4S BMS Only) Copyright EV Assemble. All Rights Reserved.

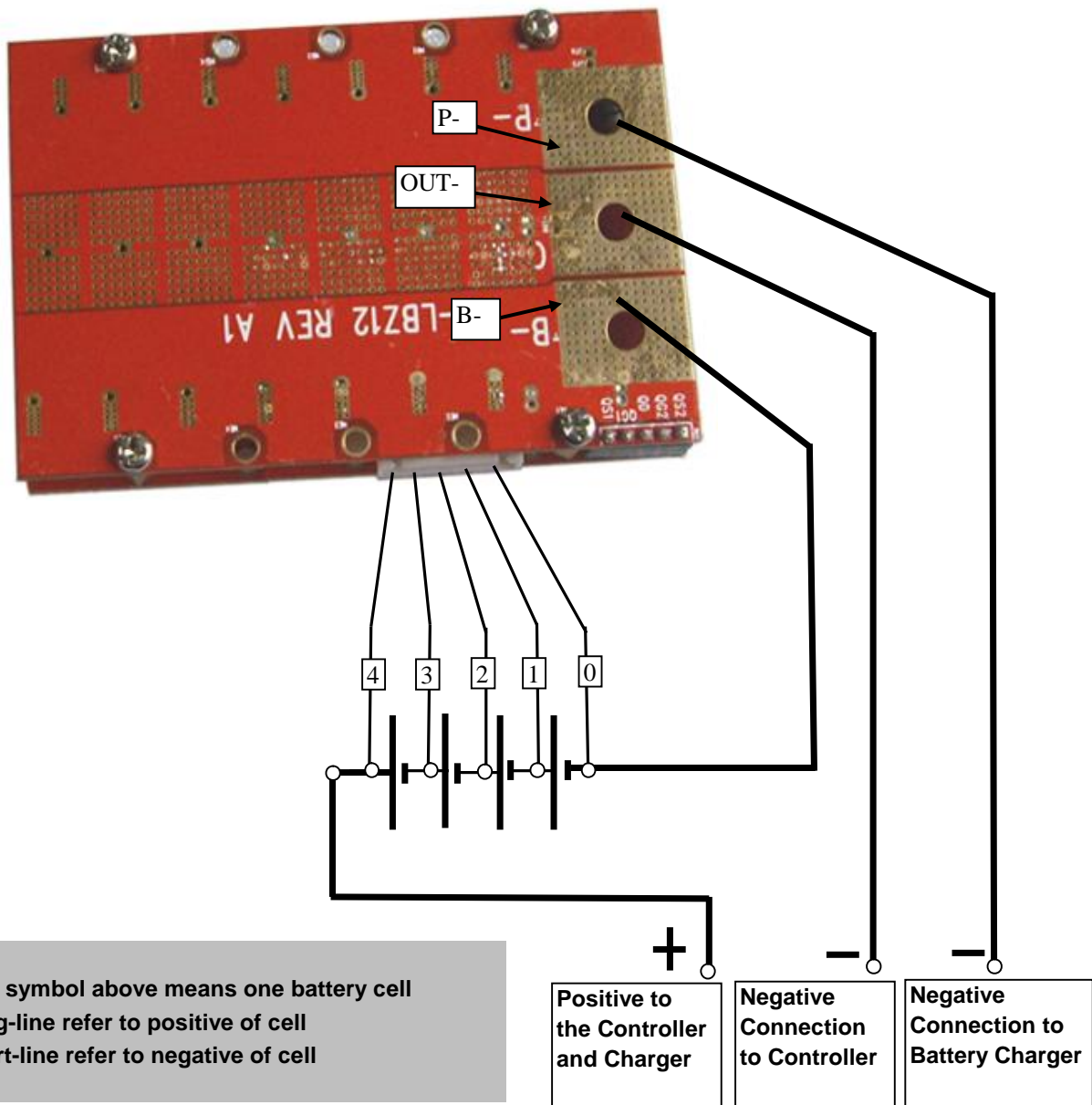

1. Make sure the wires used are of sufficient size to handle the your battery current.
2. Connect a heavy wire from B- on the BMS to the negative side of your first cell.
3. Connect a heavy wire from the terminal "Out -" to the negative terminal on your controller or power consumption equipment.
4. Connect a heavy wire from the terminal "P-" to the negative terminal of your charger.
5. Do not connect the BUS connector to the BMS yet. By keeping all wires the same length, you will assure accurate sensing voltage by the BMS.
6. Connect the sensor wire 0 to the negative terminal of 1st cell, then sensor wire 1 to positive terminal of 1st cell, sensor wire 2 to positive terminal of 2nd cell till all wires are connected exactly as shown in the block diagram. Double check your wiring to make sure you have not made a mistake. Using a multimeter with the negative probe in #0 of the BMS connector, and positive probe in #1, you will see the voltage of one cell. Leave the negative probe in #0 and check #1, #2, #3 up to #4 and you will see the voltage increase in almost equal increments. If you do not, you have made a mistake. Find the mistake and correct it.
7. Plug the connector into the BMS.

Notice:

Note;

1. Make sure all connections and wires are sized correctly to handle the current. Make sure the voltage drop across all connections between the cells are approximately the same.
Don't use a fuse between the cells or in the sensor wires.
2. Keep the BMS well ventilated.
3. Do not mount it on flammable material.
4. The maximum operating temperature of the BMS is 85°C. 185°F

FAQ:

1) Which is the 1st cell?

A: The 1st cell is the one on the far right in the diagram. It's the same cell to which you connect the B- of the BMS.

2) Is sensor wire 0 the one on the far right on diagram above?

A: Yes, it's the wire we mark "0". It's the only sensor wire which connects to the negative terminal.

3) Does Positive discharge wire come off of last cell's positive post?

A: Yes.

4) Can Charge and Discharge share the same positive wire?

Yes, if it's not convenient for your application, you can connect two wires to the positive side of the last cell. One as the positive connection to the Controller and the other one as the positive connection to Battery Charger.

5) Is '-P' the negative connection to the charger?

Yes, please connect this to the negative of charger.

6) Is 'OUT-' the negative discharge point?

Yes, you will need to connect this to negative terminal on your controller or motor.

7. If you do not COMPLETELY understand all of the above, STOP, before you damage your BMS, Battery or Controller. Get help from a knowledgeable person.